



Aspire Advanced Software Solutions & Integration (2005)

OPTIMUS

System Architecture

Revision 1.0

This document is the property of *Aspire Advanced Solutions* and all the rights are reserved to *Aspire Advanced Solutions Ltd*. Information contained herein will not be published, will not be duplicated, and no use, either full or partial will be made thereof for any purpose without the appropriate approval



Table of Contents

Scope	3
Concepts and Abbreviations	4
Optimus Server Architecture Overview	6
System Architecture Overview	8

This document is the property of *Aspire Advanced Solutions* and all the rights are reserved to *Aspire Advanced Solutions Ltd*. Information contained herein will not be published, will not be duplicated, and no use, either full or partial will be made thereof for any purpose without the appropriate approval



Scope

The purpose of this document is to provide a comprehensive architectural overview of the Aspire Advanced Solutions Optimus product and its supporting infrastructure

The architecture described in this document is the most common and recommended architecture and any changes made with the suggested architecture should be first consulted with the local dealer.

This Optimus document refers to Optimus version 0.20 and no other prior or later versions. For other versions please refer to the correct System Manual.

Clarification: All male-oriented references in this document are intended for both male and female readers and users.

This document is the property of *Aspire Advanced Solutions* and all the rights are reserved to *Aspire Advanced Solutions Ltd*. Information contained herein will not be published, will not be duplicated, and no use, either full or partial will be made thereof for any purpose without the appropriate approval

Concepts and Abbreviations

- **Optimus Server:** The PC server where Optimus Call Center is installed, using Microsoft Windows 2000/2003 Server OS software.
- **TAPI:** Telephony API (Application Programming Interface): telephony protocol supplied by Microsoft as part of the Windows OS and used by PBX vendors for application access.
- **TSP / TAPI Server:** TAPI Service Provider: The software developed by the PBX vendor using the TAPI protocol, to enable application access to the PBX. For Optimus, the LGN TSP is installed on the Optimus Server.
- **Optimus Main Device (OMD):** Optimus uses a smart LG-Nortel extension to handle waiting calls. This extension should be an LDP-30 telephone device, and DSS units are added as needed for call center with more than one PRI (or E1) interfaces.
- **Smart Extension:** An extension of the PBX supporting a smart, digital phone set. A smart extension has many features available through the PBX, which a regular extension does not.
- **Regular Extension:** An extension of the PBX supporting a regular, analog phone set. A regular extension usually supports only simple telephony functions, not unlike a traditional home telephone.
- **DSS:** An extension of a smart telephone set, providing more buttons and allowing the set to handle more calls simultaneously.
- **TN:** A unique, physical identification of an extension in the PBX.
- **CLAN:** Customer LAN. The main local network of the customer.
- **PLAN:** PBX LAN. A network segment where the LGN PBX and the Optimus Server are located. See Optimus Architecture diagram (Appendix A) for more details.
- **PBX:** Private Branch Exchange.
- **IP Address:** TCP/IP network protocol assigns a unique IP (Internet Protocol) address for each computer or device (such as the PBX).
- **IP Port Number:** TCP/IP network protocol uses different port numbers for different types of communications. For example, the HTTP protocol used for web browsing uses TCP/IP port 80, the SMTP protocol for email transfer uses port 25, and so forth.



- **DNIS:** Destination Number Identification Service, provided for each call and designates the number that was dialed in order to reach the call's destination.
- **CLID / ANI:** Caller ID, provided for each call and identifies the caller's number (unless the number is blocked purposefully).
- **ATTACHDATA:** Any additional data (besides DNIS and CLID) attached to the call. For example: Customer ID as entered by the caller using the phone's buttons.
- **SPIN:** Screen Pop-up Integration. An Aspire product used for tight and closer integration, used mainly for Client/Server software.
- **ODBC:** Open Data Base Connectivity – a MS-Windows standard for database access and connections. Supported by most commercial database software.

This document is the property of *Aspire Advanced Solutions* and all the rights are reserved to *Aspire Advanced Solutions Ltd*. Information contained herein will not be published, will not be duplicated, and no use, either full or partial will be made thereof for any purpose without the appropriate approval

Optimus Server Architecture Overview

Graphical Overview

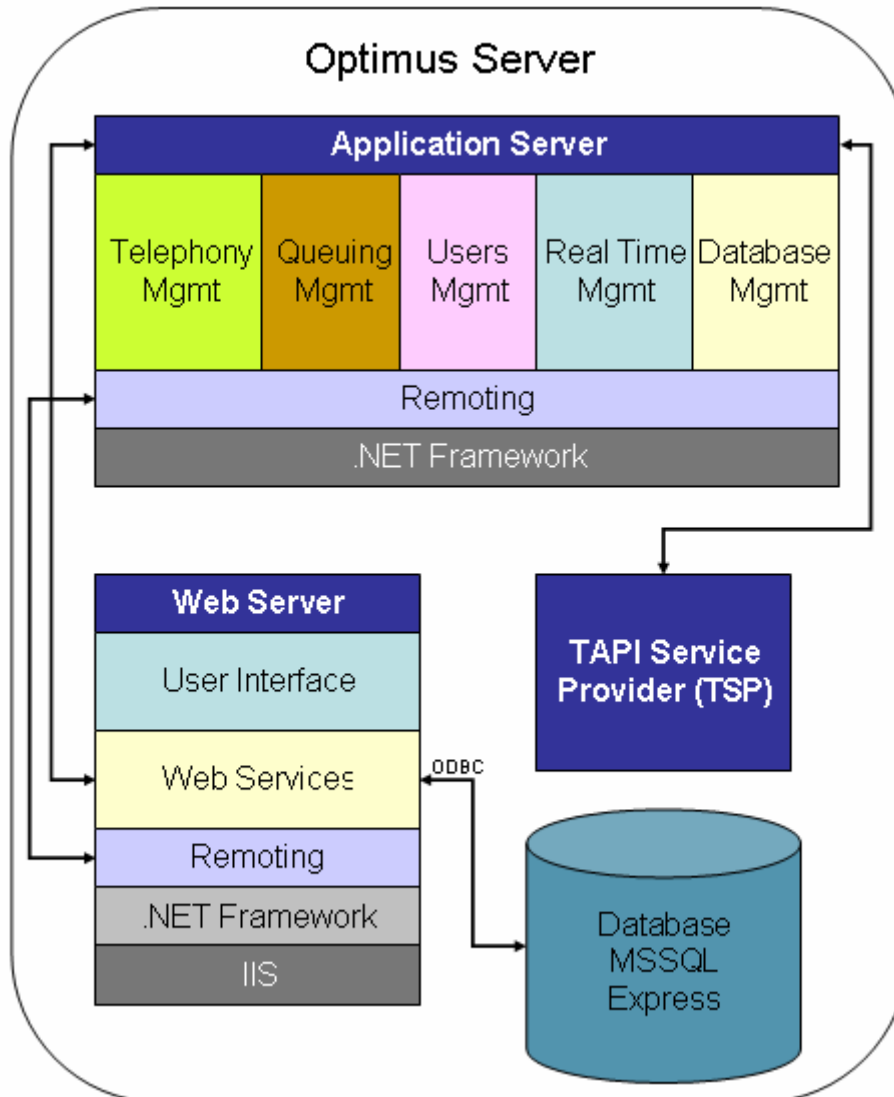



Components Description

The Optimus server contains the application server, the web server, the database (MSSQL Express) and the TSP (TAPI Service Provider).

The application consists of several windows services and is written using .Net Framework. The web server contains the graphical user interface and all the web services, both written using .Net Framework. The database is Microsoft SQL Server Express.

The application server and the GUI interact using .NET Remoting (.NET Remoting is an enabler for application communication. It is a generic system for different applications to use to communicate with one another). Although it is recommended to install both on the same machine, the application server and the web server can be located on different computers on the same network

The web server is Microsoft IIS (Internet Information Services) and contains the graphical user interface (GUI) - Optimus Management System and the web services. The GUI requires Microsoft Internet Explorer to be installed on each client machine.

The web services are used for database access via ODBC (Open Database Connectivity).

Optimus server is installed on Microsoft Windows 2000 Server or Microsoft Windows 2003 Server only.

System Architecture Overview

Graphical Overview

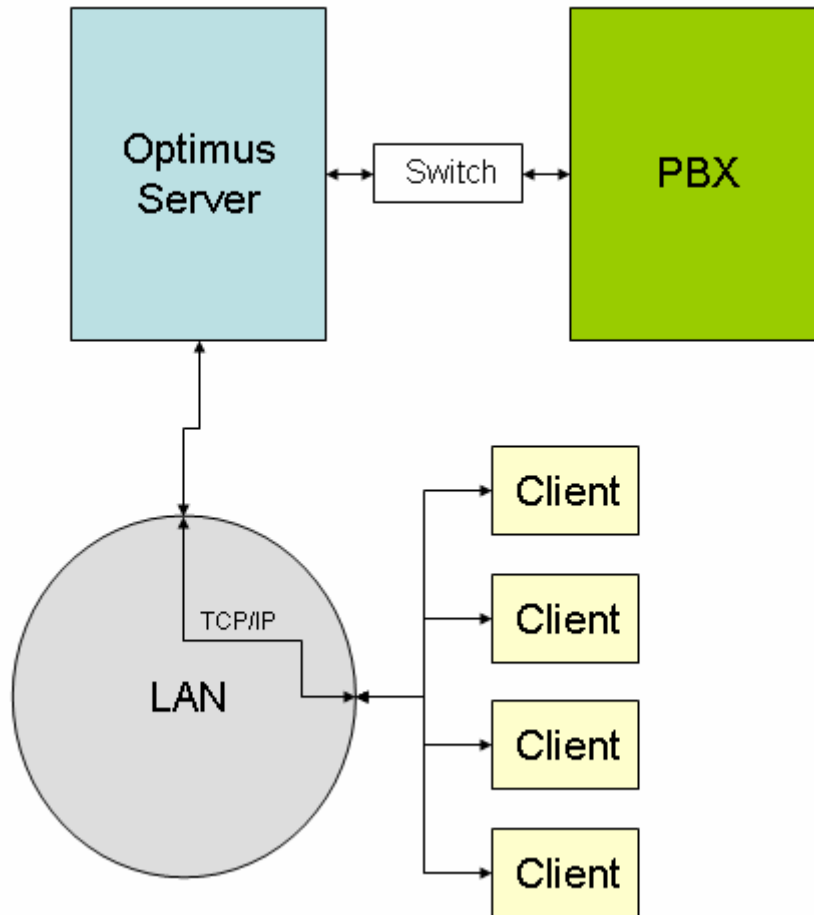

Components Description

The Optimus server has two network adapters. The first one is connected to a switch and is used to communicate with the PBX, which is also connected to the same switch. Both IP addresses of the Optimus server and the PBX should be of the same class c IP network.

The second adapter is used to connect the Optimus server to the LAN (Local Area Network). All the client machines are also connected to the LAN and communicate with Optimus using TCP/IP.